

CL212S HIGH-POWER 300 W 2 x 12" SUBWOOFER SYSTEM

EUROCOM Installed Sound

CL212S Features:

- Exceptional sound quality with ultra-low frequency extension and linear response
- Dual 150-Watt 12" low-frequency transducers provide deep bass for medium sized rooms
- By-passable internal passive crossover for use with full range input signal
- Dual professional speaker connectors (compatible with Neutrik Speakon connectors) and 4-position terminal strip
- Internally braced and acoustically inert rectangle birch plywood enclosure ideal for array applications
- Multiple threaded inserts for flexible and secure installation
- Powder coated steel grille wrapped with acoustically transparent fabric and foam matching cabinet color
- Available in black



Product Overview:

The EUROCOM CL212S is a professional high-performance ultra-low-frequency subwoofer system that is ideal for a wide variety of fixed installation applications. Compact yet powerful, the CL212S features clean lines and a unique fabric-finished wrap-around grille for a refined appearance that complements even the most elegant rooms. The unit's modular design allows deployment individually, in pairs, or in larger low-frequency arrays, making it easy to tailor systems to the specific requirements of the venue. Delivering deep, powerful lows in mid-to-large-sized spaces, the CL212S is perfect for theaters and auditoria, performing arts centers, clubs and discotheques, houses of worship, themed entertainment, and sporting arenas and stadiums.

The CL212S is housed in a rectangular enclosure of acoustically inert high-quality laminated Baltic birch plywood. Internal steel bracing enhances the cabinet's natural rigidity and provides a set of integrated threaded mounting-point inserts. A rated load factor of at least 10 times overall cabinet weight makes the CL212S an exceptionally safe choice for flown installation.

The CL212S achieves fully professional performance and reliability with newly-designed components whose frequency response, sensitivity, and power handling are all custom tailored for CL Series loudspeakers. BEHRINGER

CL212S Technical Specifications:

Frequency range (-10 dB)	33 Hz - 500 Hz
Frequency response (+/-3 dB)	37 Hz - 200 Hz
Sensitivity (1 W @ 1 m passive)	99 dB (half space)
Crossover modes	Bypassable
Crossover frequency	200 Hz
Power capacity (long term, IEC passive)	300 W RMS @ 34.6 V
Maximum continuous SPL (passive)	124 dB @ 1 m
Maximum peak SPL (passive)	130 dB @ 1 m

Transducers:

Nominal impedance	4 Ω
Low frequency driver	2 x 12" @ 150 W



CL212S HIGH-POWER 300 W 2x12" SUBWOOFER SYSTEM

EUROCOM Installed Sound

Overview continued:

maintains complete control over quality and sonic character by manufacturing all CL Series components—starting with the pulp used for cone fabrication—in our own factories.

Featuring two 12" woofers with 300 W long-term power-handling, the CL212S accurately reproduces even the most demanding low-end material for a clean, full sound. A built-in passive crossover maximizes flexibility by band-splitting the output of a single amplifier channel to power both the CL212S and a full-range loudspeaker.

Every aspect of the CL212S has been thought through to maximize value and convenience for both the installer and the end user. The result is an attractive, durable subwoofer system that delivers deep, satisfying low-end for any installation application.

CL212S Technical Specifications continued:

Enclosure	Rectangle, laminated birch plywood
Grille	Steel
Rigging points	16 X M10 threaded rigging points
Termination	NL4 and 4-position terminal strip connection
Dimensions (H x W x D)	15.4 x 35.9 x 16.6" / 392 x 912 x 421 mm
Weight	73.4 / 33.3 kg

Dimensional Drawings:

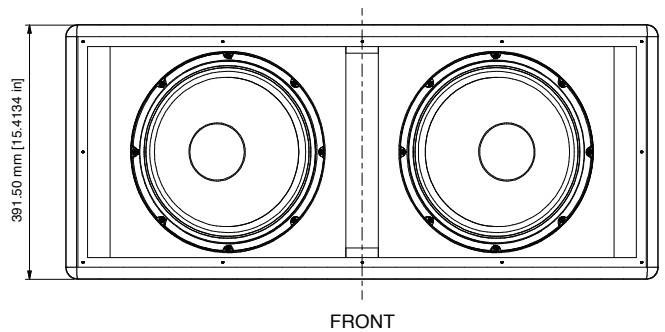
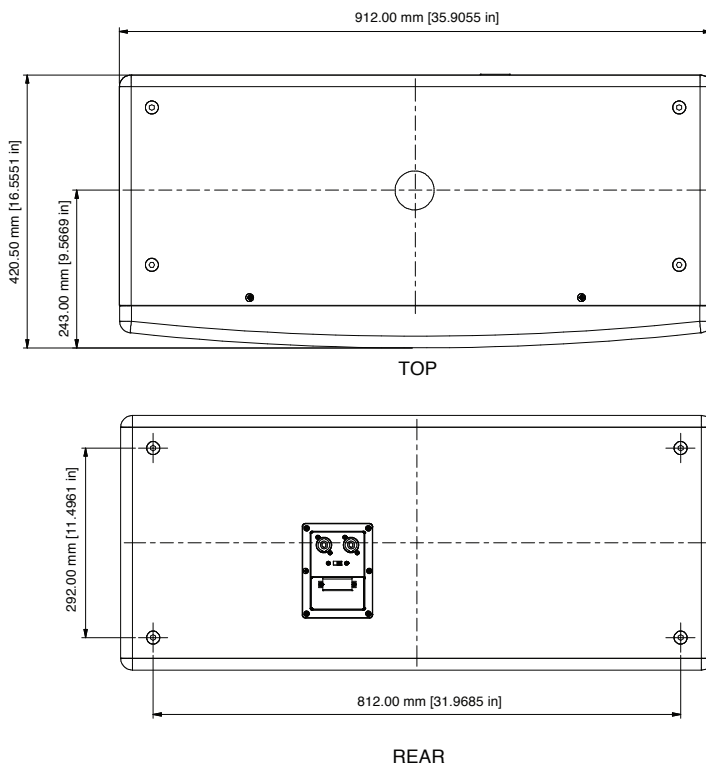

CL212S HIGH-POWER 300 W 2 x 12" SUBWOOFER SYSTEM

EUROCOM Installed Sound

FREQUENCY RESPONSE, 1 W @ 1 M

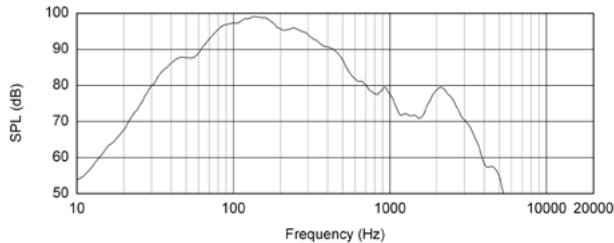

IMPEDANCE VS. FREQUENCY

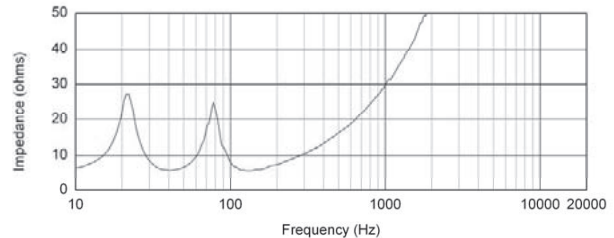

Architect's and Engineer's Specifications:

The loudspeaker shall be a professional fixed-installation subwoofer system in a steel-braced plywood enclosure with a 2 x 12" (305 mm) low-frequency cone transducer.

Driver for the subwoofer system shall be a dual 12" (305 mm) direct-radiating cone transducer.

Enclosure for the subwoofer system shall be constructed of laminated birch plywood that is internally braced with steel. The enclosure shall be finished with durable, scuff-free black paint. The front of the enclosure shall be protected with a perforated grille of powder-coated structural steel behind fabric-wrapped acoustically transparent foam. The back of the enclosure shall have a recessed steel input plate for connectors.

Rigging of the subwoofer system shall be with 16 M10 threaded rigging points fitted to the exterior, four on each end.

Connections to the subwoofer system shall include the following:

- Two NL4 connectors, wired in parallel as band-limited input to the passive crossover
- One 4-position terminal strip with captive wire clamps and removable plastic cover, with IN terminals wired in parallel to OUT terminals and to the NL4 connectors
- Crossover bypass as a detachable connector on the crossover PCB, allowing direct connection to each driver

Performance criteria met by the subwoofer system shall include:

- Nominal impedance of 4 Ω
- Sensitivity (1 W/1 m passive, half-space) of 99 dB
- Usable frequency range (-10 dB) of 33 Hz - 500 Hz
- Frequency response (+/-3 dB) of 37 Hz - 200 Hz
- Power Handling (IEC268-5, passive) of 300 W RMS @ 34.6 V
- Maximum SPL (1 m, passive) of 124 dB continuous and 130 dB peak

Physical characteristics of the subwoofer system shall be:

- Height x Width x Depth of 15.4 x 35.9 x 16.6" (392 x 912 x 421 mm)
- Net weight of not more than 73.4 lbs (33.3 kg)

The subwoofer system shall be the BEHRINGER EUROCOM CL212S.